



Over Voltage and Over Current Protection IC

General Description

The LP5300 is an Over-Voltage-Protection (OVP) and Over-Current-Protection (OCP) device. The device will switch off internal MOSFET to disconnect VIN to VOUT to protect load when any of input voltage, input current over the threshold. The Over temperature protection (OTP) function monitors chip temperature to protect the device.

The LP5300 is available in SOT-23-6L and SOT89 package. Standard products are Pb-free and Halogen-free.

Features

- ◆ Input Voltage Range: 3.5V to 36V
- ◆ Typical Output Power on Time: 9ms
- ◆ OVP Threshold: 6.1V
- ◆ OVP Threshold Time Less Than 1μs
- ◆ Over Current Protection: 2.1A(MIN)
- ◆ Low R_{DS(ON)} Internal Switches:130mΩ @ 5V /1A
- ◆ Output Discharge
- ◆ Thermal Fault Protection
- ◆ SOT23-6/SOT89 Package
- ◆ RoHS Compliant and 100% Lead (Pb)-Free

Order Information

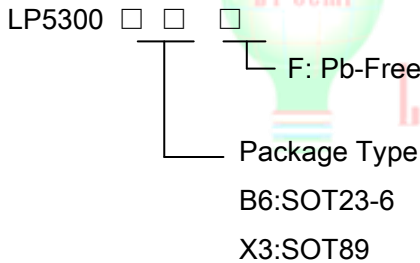

Typical Application Circuit

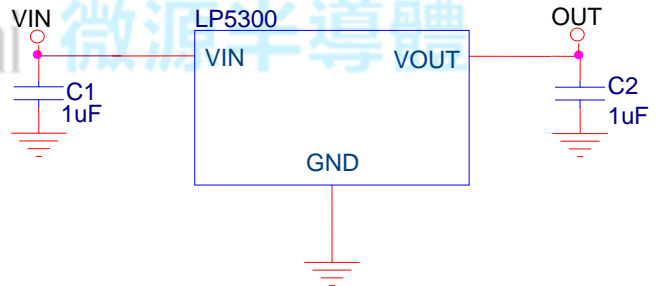

Applications

- ◇ GPS
- ◇ PMP
- ◇ PAD
- ◇ MID
- ◇ Digital cameras, Digital Videos

Marking Information

Device	Marking	Package	Shipping
LP5300B6F	LP5300 8WYWXX	SOT23-6	3K/REEL
LP5300X3F	LPS LP5300 YWX	SOT89	1K/REEL

Marking indication:

Y:Production year W:Production week X:Production batch



Functional Pin Description

Top View

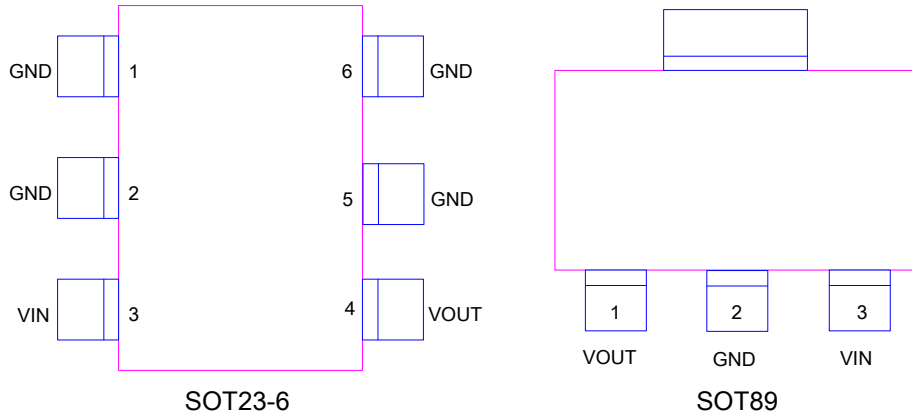

Pin Description

Pin		Name	Description
SOT23-6	SOT89		
1,2,5,6	2	GND	Ground.
3	3	VIN	Input pin. A 1uF low ESR ceramic capacitor or larger must be connected as close as to this pin. It is recommended to use 50V capacitor or according to application.
4	1	VOUT	Output pin.



Function Diagram

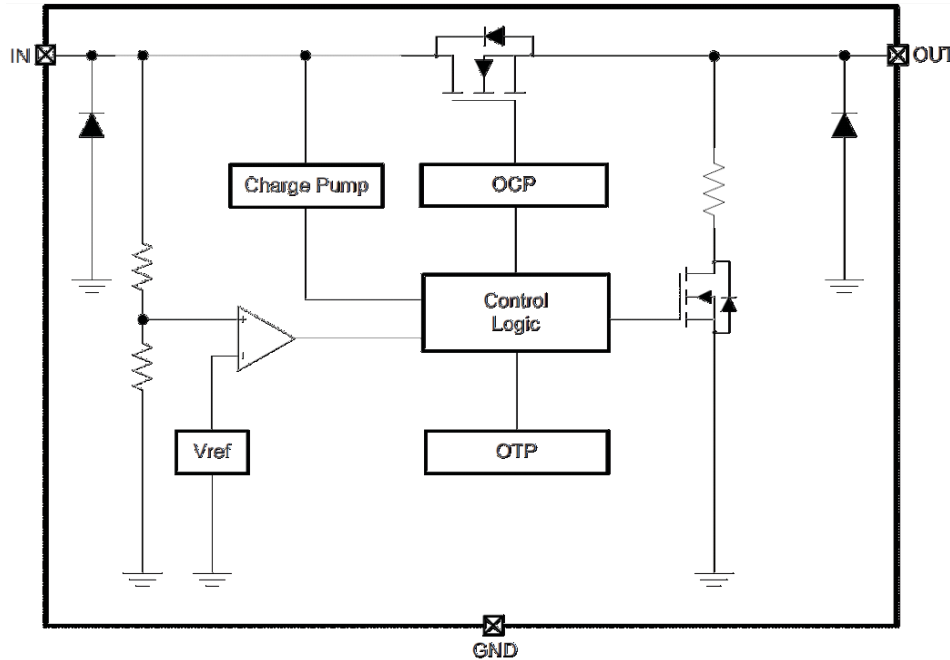

Absolute Maximum Ratings ^{Note 1}

- ◇ Input Voltage to GND ----- 36V
- ◇ Output Voltage to GND ----- 6.5V
- ◇ Maximum Junction Temperature ----- 150°C
- ◇ Maximum Soldering Temperature (at leads, 10 sec) ----- 260°C

Note 1. Stresses beyond those listed under “Absolute Maximum Ratings” may cause permanent damage to the device. These are stress ratings only, and functional operation of the device at these or any other conditions beyond those indicated in the operational sections of the specifications is not implied. Exposure to absolute maximum rating conditions for extended periods may affect device reliability.

Thermal Information

- ◇ Maximum Power Dissipation (SOT23-6, P_D, T_A=25°C) ----- 0.45W
- ◇ Thermal Resistance (SOT23-6, θ_{JA}) ----- 250°C/W
- ◇ Maximum Power Dissipation (SOT89, P_D, T_A=25°C) ----- 0.7W
- ◇ Thermal Resistance (SOT89, θ_{JA}) ----- 165°C/W

ESD Susceptibility

- ◇ HBM(Human Body Mode) ----- 2KV
- ◇ MM(Machine Mode) ----- 200V

Recommended Operating Conditions

- ◇ Operating Ambient Temperature Range (T_A) ----- -40°C to 85°C
- ◇ Operation Junction Temperature Range ----- -40°C to 125°C



Electrical Characteristics

T_A=25°C, unless otherwise noted

Symbol	Parameter	Condition	Min	Typ	Max	Units
DC characteristics and Power-ON-Reset						
V _{IN}	Input Voltage		3.5		36	V
I _Q	Input quiescent current	V _{IN} =5V, I _{OUT} =0A		80		μA
R _{ON}	VIN-to-VOUT ON resistance	V _{IN} =5V, I _{OUT} =1A		130	145	mΩ
R _{DISCHARGE}	Output discharge resistance			3.6		KΩ
UVLO	Under voltage lock out threshold	V _{IN} increasing from 0~3V	2.6	2.8	3	V
V _{HYS-UVLO}	Under voltage lock out hysteresis	V _{IN} decreasing from 3~0V		150		mV
T _{ON}	Output power-on time	V _{IN} =0→5V to output ON		9		ms
Input Over-Voltage-Protection (OVP)						
V _{OVP}	OVP threshold	V _{IN} increasing from 5~7V	5.8	6.1	6.4	V
V _{HYS-OVP}	OVP hysteresis	V _{IN} decreasing from 7~5V		300		mV
T _{OVP}	OVP active time	V _{IN} =5→10V			1	μs
T _{ON(OVP)}	OVP recovery time	V _{IN} =10→5V to output ON		9		ms
Input Over-Current-Protection (OCP)						
I _{OCP}	OCP threshold		2.1	2.5		A
t _{OCP}	OCP active time			30		ms
t _{ON(OCP)}	OCP recovery time			1		s
Over-Temperature-Protection (OTP)						
T _{OTP}	OTP threshold			150		°C
T _{OTP_HYS}	OTP hysteresis			20		°C



Typical Operating Characteristics

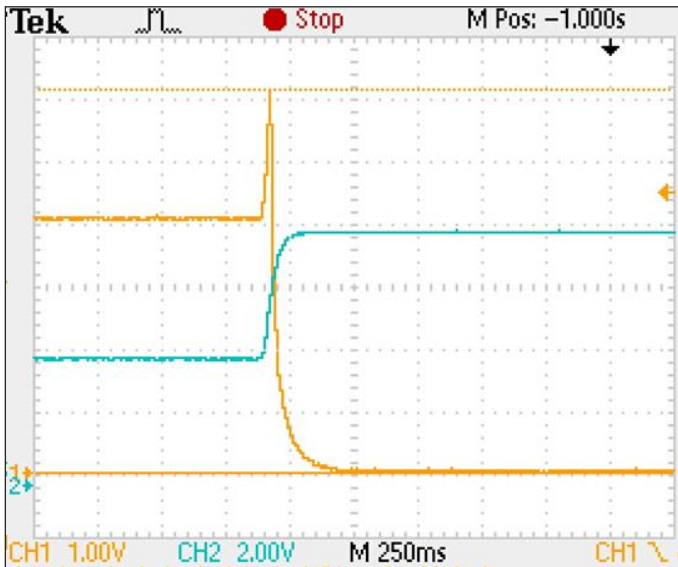
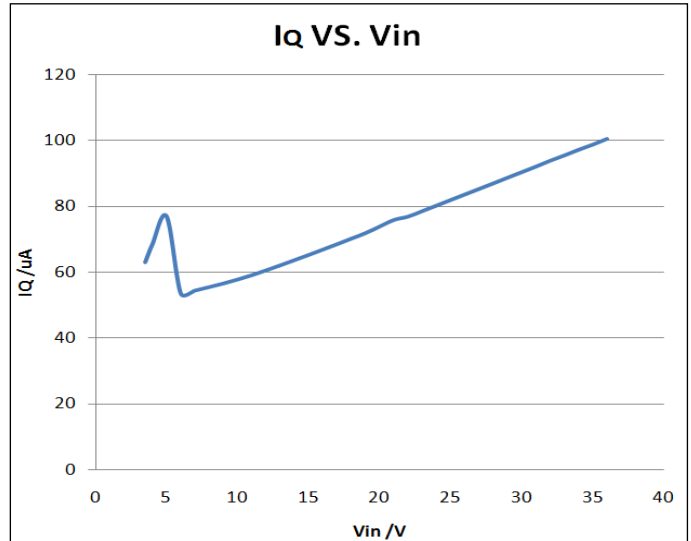
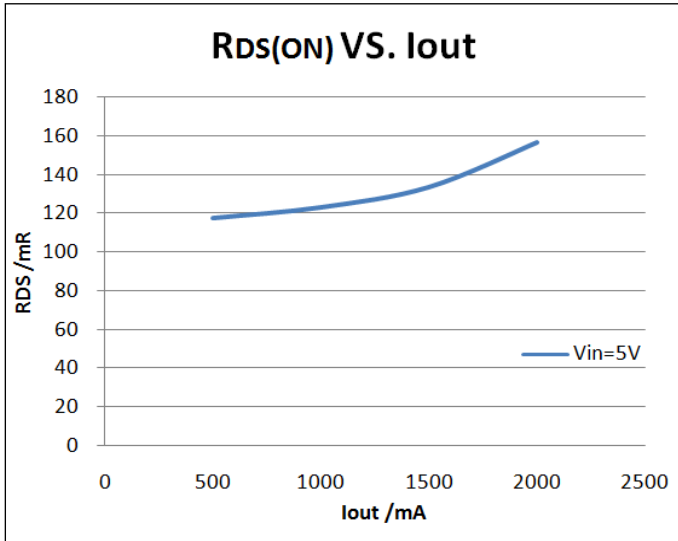

OVP waveform



VIN falling waveform



Packaging Information

SOT23-6

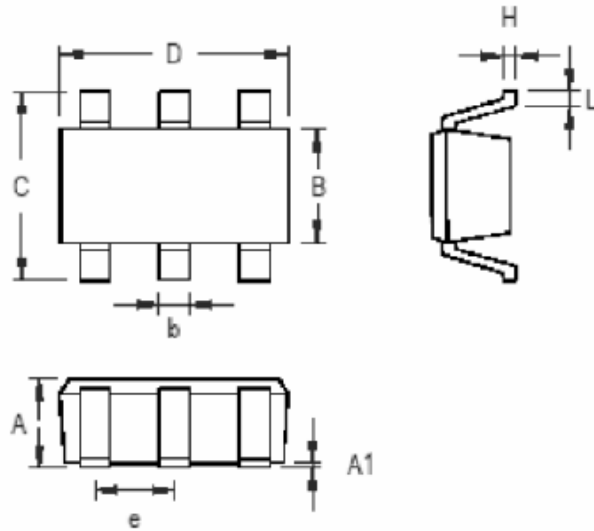

Symbol	Dimensions In Millimeters		Dimensions In Inches	
	Min	Max	Min	Max
A	0.889	1.295	0.031	0.051
A1	0.000	0.152	0.000	0.006
B	1.397	1.803	0.055	0.071
b	0.250	0.560	0.010	0.022
C	2.591	2.997	0.102	0.118
D	2.692	3.099	0.106	0.122
e	0.838	1.041	0.033	0.041
H	0.080	0.254	0.003	0.010
L	0.300	0.610	0.012	0.024

SOT-23-6 Surface Mount Package



SOT89

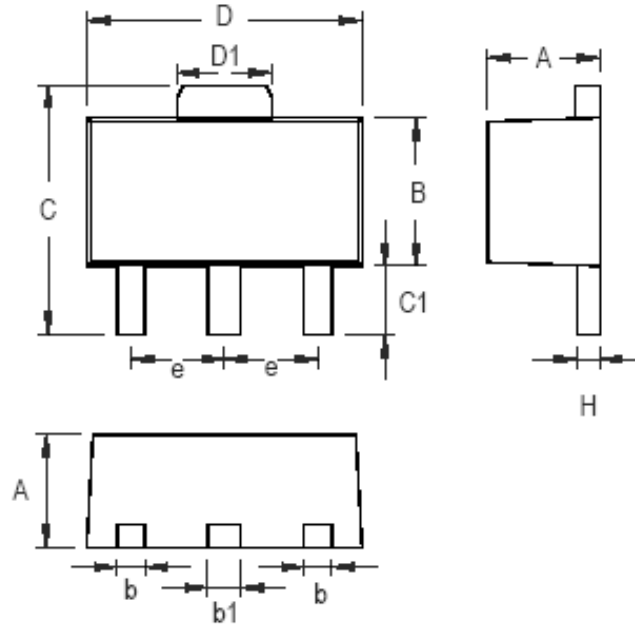

Symbol	Dimensions In Millimeters		Dimensions In Inches	
	Min	Max	Min	Max
A	1.397	1.600	0.055	0.063
b	0.356	0.483	0.014	0.019
B	2.388	2.591	0.094	0.102
b1	0.406	0.533	0.016	0.021
C	3.937	4.242	0.155	0.167
C1	0.787	1.194	0.031	0.047
D	4.394	4.597	0.173	0.181
D1	1.397	1.753	0.055	0.069
e	1.448	1.549	0.057	0.061
H	0.356	0.432	0.014	0.017

3-Lead SOT-89 Surface Mount Package